

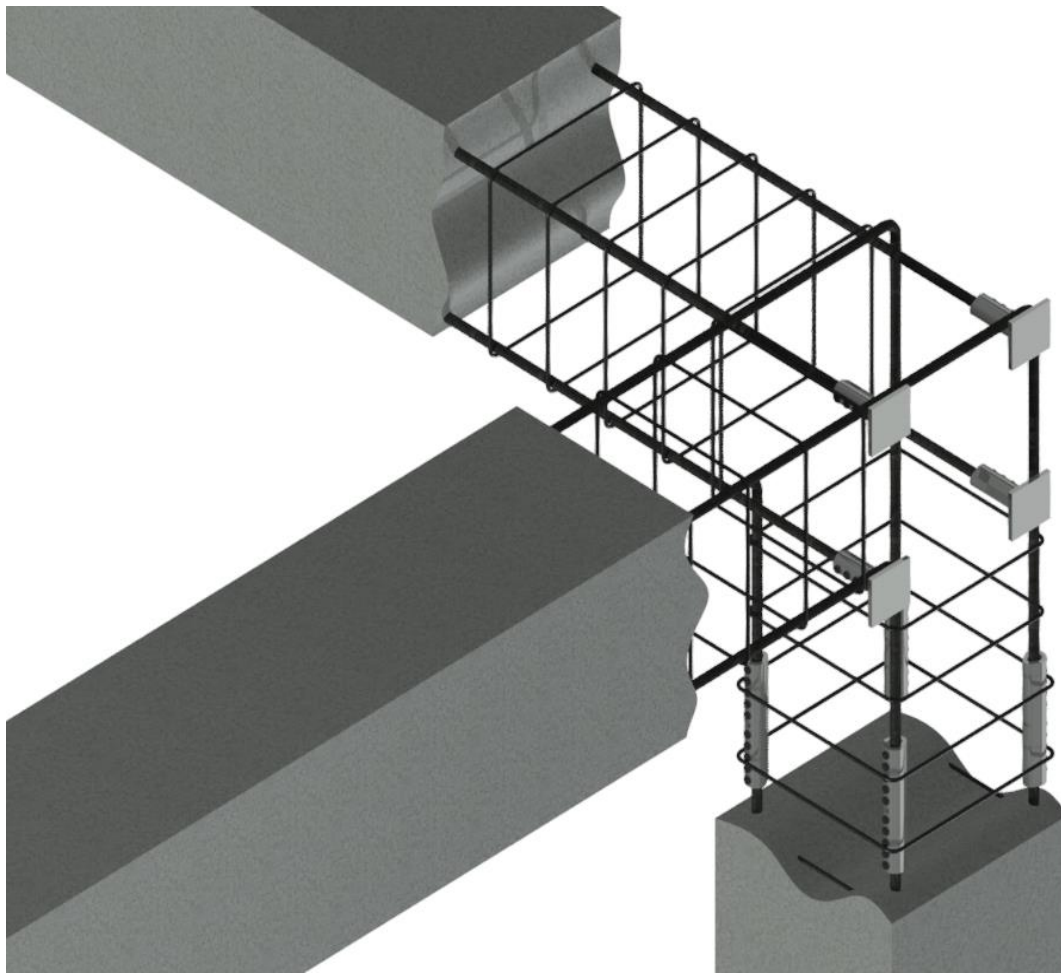



## TECHNICAL DOCUMENTATION



## REINFORCEMENT SYSTEMS | **ALLIGATOR COUPLERS**

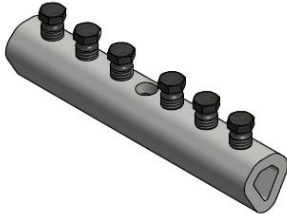
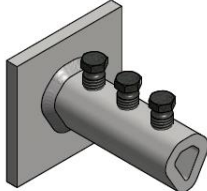
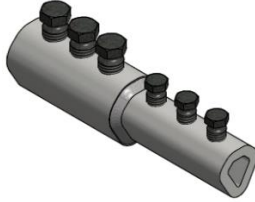
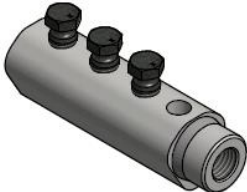
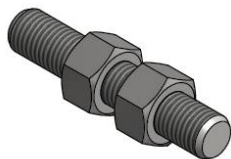
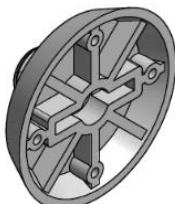

**PRODUCT RANGE**

<b>COUPLERS</b>		
<p><b>ALC</b></p>  <p>Page 6</p>	<p><b>ALC – AP</b></p>  <p>Page 9</p>	<p><b>ALC – VK</b></p>  <p>Page 11</p>
<p><b>ALC – SK</b></p>  <p>Page 13</p>	<p><b>PSK</b></p>  <p>Page 14</p>	
<b>ACCESSORIES</b>		
<p><b>KU-10</b></p>  <p>Page 15</p>	<p><b>SN</b></p>  <p>Page 16</p>	
<b>TOOLS</b>		
<p><b>ELECTRIC WRENCH</b></p>  <p>Page 21</p>	<p><b>PNEUMATIC WRENCH</b></p>  <p>Page 21</p>	<p><b>TERWA WRENCH</b></p>  <p>Page 19</p>

**TABLE OF CONTENTS**

<b>PRODUCT RANGE</b> .....	<b>2</b>
<b>INTRODUCTION</b> .....	<b>4</b>
<b>THE MAIN APPLICATIONS FOR ALLIGATOR COUPLERS</b> .....	<b>5</b>
<b>ALLIGATOR COUPLING – ALC</b> .....	<b>6</b>
<b>MOUNTING INSTRUCTIONS FOR ALC COUPLER</b> .....	<b>7</b>
<b>MOUNTING INSTRUCTIONS FOR AN ALC ALLIGATOR COUPLER – REPAIR OF AN EXISTING STRUCTURE</b> .....	<b>8</b>
<b>ALLIGATOR END COUPLER – ALC-AP</b> .....	<b>9</b>
<b>MOUNTING INSTRUCTIONS FOR ALC-AP COUPLER</b> .....	<b>10</b>
<b>TRANSITION COUPLER – ALC-VK</b> .....	<b>11</b>
<b>MOUNTING INSTRUCTIONS FOR ALC-VK COUPLER</b> .....	<b>12</b>
<b>CONTINUITY COUPLER – ALC-SK</b> .....	<b>13</b>
<b>CONTINUITY COUPLER – PSK – MALE COMPONENT</b> .....	<b>14</b>
<b>PLASTIC NAILING PLATE KU-10</b> .....	<b>15</b>
<b>DOUBLE THREADED SCREW PLUG SN</b> .....	<b>16</b>
<b>MOUNTING INSTRUCTIONS FOR ALC-SK COUPLER WITH TSE COUPLER</b> .....	<b>17</b>
<b>MOUNTING INSTRUCTIONS FOR ALC-SK COUPLER</b> .....	<b>18</b>
<b>TERWA TORQUE WRENCH</b> .....	<b>19</b>
<b>TOOLS FOR ALLIGATOR COUPLERS</b> .....	<b>20</b>
<b>CONTACT</b> .....	<b>22</b>
<b>DISCLAIMER</b> .....	<b>22</b>

## INTRODUCTION

The ALLIGATOR coupler is used for splicing any grade or profile of reinforcing steel bar. These couplings are mechanical connectors for reinforcing steel with diameters between 10 mm and 40 mm. Connection is made by inserting bars into both ends of the coupler. The breaking bolts are then screwed on manually and tightened with a ratchet wrench until the bolts shear off. In specific cases, these couplers can be used to replace the damaged reinforcements with new ones and to connect to the old structure.

The advantages of ALLIGATOR COUPLERS are as follows:

- Ensure integral connection for steel reinforcement.
- There is no need for threading or any other bar preparation.
- They are fast, simple, and easy to use.
- The use of ALC rules out the use of lap splices resulting in less congestion and saves rebar material.
- No special training needed.
- Do not have any welded components.
- Correct assembly is easy to check visually.

### Quality

Terwa continuously controls the anchor production process in terms of strength, dimensional and material quality, and performs all of the required inspections for a superior quality system. All of the products are tracked from material acquisition to the final, ready to use product.



### Marking and traceability

All systems have all necessary data for traceability, rebar diameter and product name.

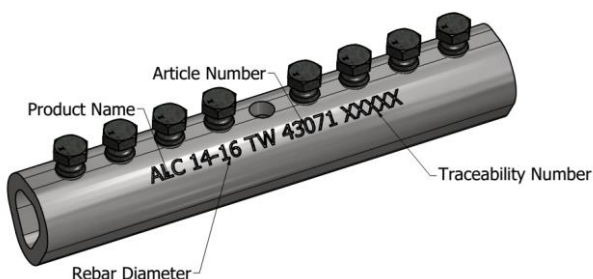

### Coupler testing

Terwa rebar couplers are designed to ensure the full transfer of the load to the reinforcement steel and a slip value under 0.1 mm. Terwa periodically tests the system for this in the factory according to the European standards.

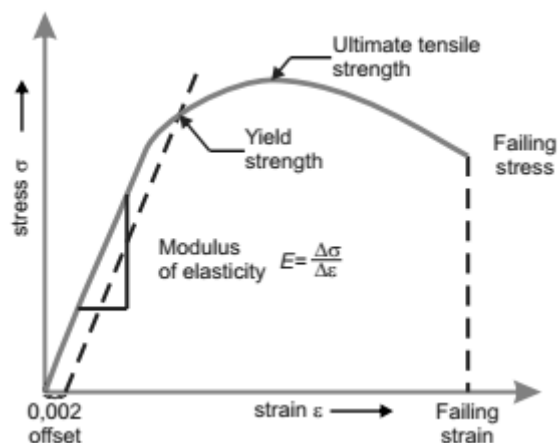

## THE MAIN APPLICATIONS FOR ALLIGATOR COUPLERS

- for column construction
- to extend or repair existing structures
- to connect precast element to precast element
- to close access openings
- for the pre-fabrication of the reinforcing bar cage
- for fatigue applications

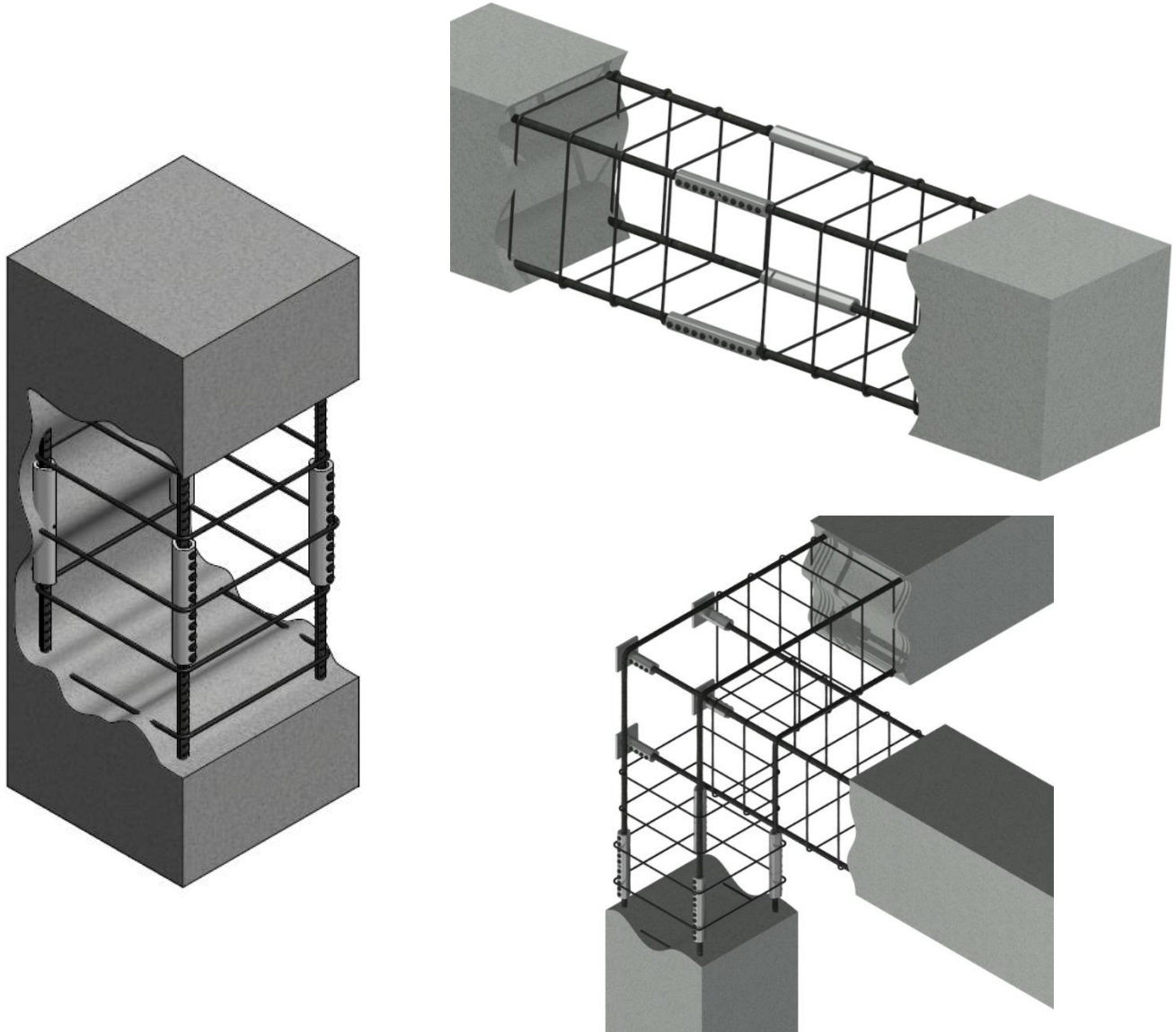

## ALLIGATOR COUPLING – ALC

The ALLIGATOR COUPLING ALC is used for the connection of reinforcing bars of the same size. The product has a pin and an inspection hole in the middle for correct installation. The breaking bolts are designed to shear off at the torque moment specified in the table below.

Tighten the bolts using a torque wrench, an impact, electric or pneumatic wrench. Please see page 20-21.

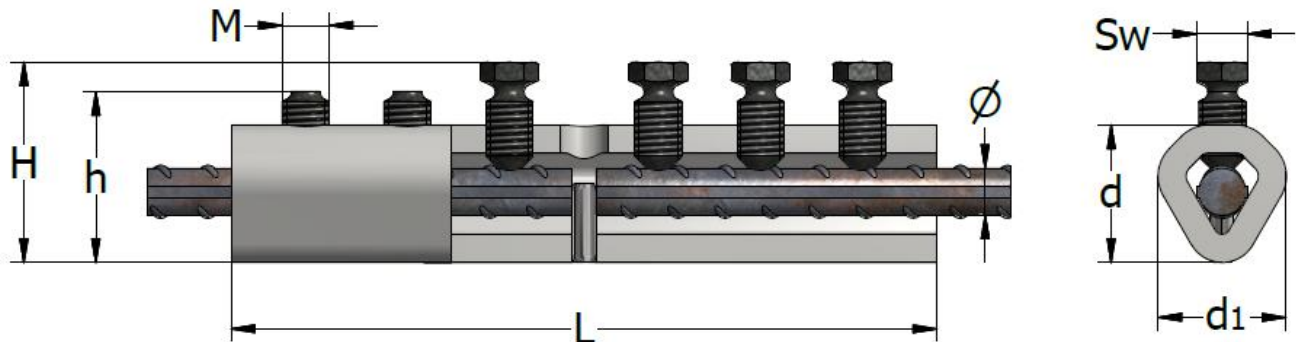

Type ALC	Product no.	Rebar Ø [mm]	Breaking bolt		Breaking bolt thread M	L [mm]	d [mm]	d1 [mm]	H Unruptured Bolt [mm]	h [mm]	SW [mm]	Torque moment [Nm]
			n	Product no.								
10	44633	10	6	50685-1	M12	160	33	34	Max. 46	36	13	95-115
12	44634	12	6	50685-1	M12	180	33	34	Max. 49	39	13	95-115
14-16	43071	14/16	8	50685-1	M12	230	37	38	Max. 55/57	45/47	13	95-115
18	43072	18	10	50685-1	M12	280	44	42	Max. 59	49	13	95-115
20-22	65681	20/22	10	50686-1	M16	290	50	50	Max. 63/67	51/55	17	190-215
25	43075	25	12	50686-1	M16	390	55	54	Max. 72	60	17	190-215
26	63079	26	12	52295	M20	420	63	62	Max. 83	68	22	355-415
28	43076	28	12	52295	M20	420	63	62	Max. 85	70	22	355-415
30	63080	30	14	52295	M20	480	70	69	Max. 87	72	22	355-415
32	43077	32	14	52295	M20	480	70	69	Max. 92	77	22	355-415
36	43078	36	16	52295	M20	540	77	74	Max. 99	84	22	355-415
40	43079	40	18	52295	M20	580	76	74	Max. 101	86	22	355-415

## MOUNTING INSTRUCTIONS FOR ALC COUPLER

- Mount the ALLIGATOR COUPLING to the reinforcement steel from one side.

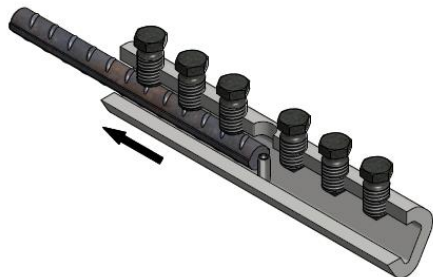

- Place the ALC coupler over the end of the first rebar and tighten the breaking bolt by hand.
- It is important to check the contact between the first rebar and the central stopper pin (visible through the inspection hole).

- Mount the second reinforcement bar in the ALLIGATOR COUPLER and tighten the breaking bolts until it shears off.



- Insert the second rebar into the coupler.
- Check the contact between the second rebar and the pin.
- Do not lubricate the bolt connection.
- Tighten the breaking bolt by hand.

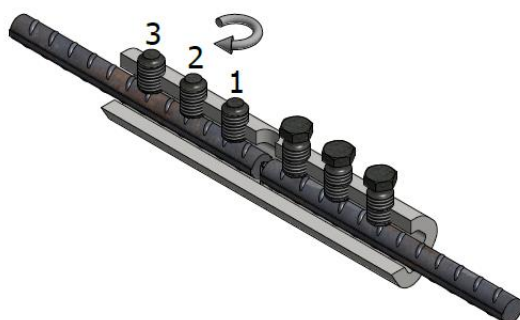

Tighten the breaking bolts completely using an electric or pneumatic wrench as described on page 20-21. The bolts must be tightened from the centre outwards (1 to 3) until the heads of all the breaking bolts shear off.

- The ALLIGATOR COUPLER in its mounted state.







Completed Alligator (ALC) coupler installation after all bolts have been sheared off. Not removing/shearing off a bolt head on one side of the coupler during installation is acceptable provided that the appropriate bolt torque is attained as detailed in the table on page 6. However, the installation is only considered satisfactory if the height H as indicated in the table on page 6 is not exceeded. This must be measured to ensure satisfactory penetration and grip of the reinforcing bar.

**Note:** When there is not enough space in the element to use a pneumatic or electric wrench, a manual torque wrench can be used to shear the bolt or to achieve the torque momentum according to the table on page 6. We recommend using a torque multiplier for breaking bolts M16 and M20.

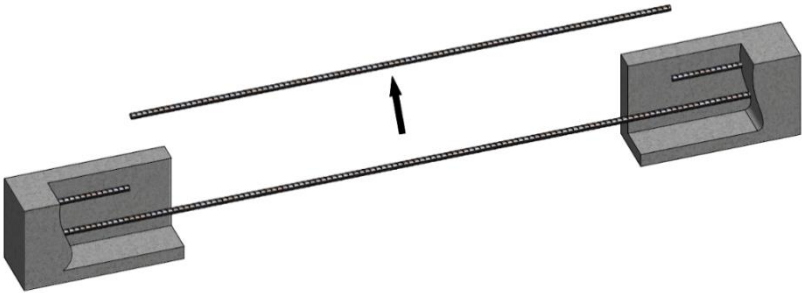
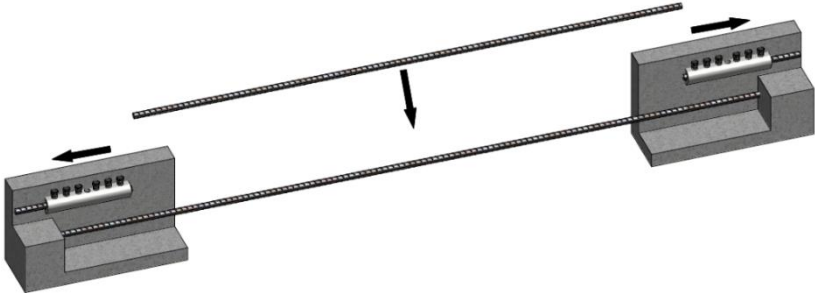
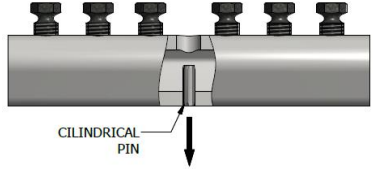
The ALC are delivered with the breaking bolts pre-mounted and should not be removed from the coupler. The wrench momentum has to be at least **2x the bolt torque**.

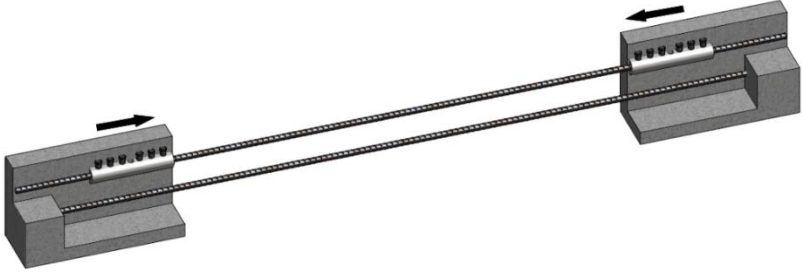
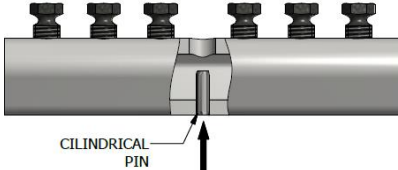
**MOUNTING INSTRUCTIONS FOR AN ALC ALLIGATOR COUPLER – REPAIR OF AN EXISTING STRUCTURE**

	<p>To repair an existing structure by replacing a corroded or damaged rebar, the replacement bar must be cut approximately 5 mm shorter to ensure easy fitting between the cut ends of the original bar.</p>
	<p>First remove the pin from the ALC. ALC couplers are fully pushed onto both ends of the existing bars and temporarily tightened onto them.</p>  <p>CILINDRICAL PIN</p>
	<p>Then position the replacement bar between the end of the existing bars and slide the ALC couplers about half a length over it. Fit the cylindrical pin back in the ALC.</p>
	 <p>CILINDRICAL PIN</p>
	<p>Then tighten the breaking bolts to shear them off.</p>



## ALLIGATOR END COUPLER – ALC-AP

The ALLIGATOR COUPLING WITH END ANCHORING is designed to ensure dead-end embedding of reinforcing steel bars in concrete. This helps to reduce the congestion and simplifies the placement of the reinforcing bars by eliminating the need for hooked ends. The ALLIGATOR END COUPLER includes half of an alligator coupling with a plate welded to one end, which will transfer the full tensile load of the bar when it bears against concrete. One advantage of this system is that there is no need for special preparation of the reinforcing bar.

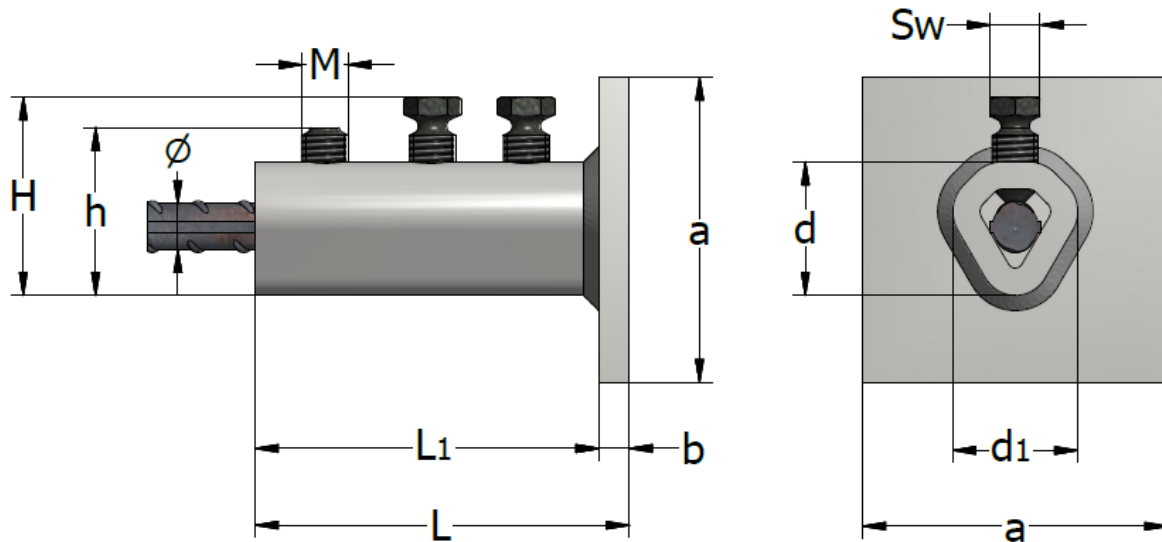

Type ALC-AP	Product no.	Rebar $\varnothing$ [mm]	Breaking bolt number n	Breaking bolt thread M	L [mm]	a [mm]	b [mm]	d [mm]	d1 [mm]	H [mm]	h [mm]	SW [mm]	Torque moment [Nm]
10	43655	10	3	M12	88	80	8	33	34	Max. 46	36	13	95-115
12	43656	12	3	M12	98	80	8	33	34	Max. 49	39	13	95-115
14-16	43658	14/16	4	M12	123	100	8	37	38	Max. 55/57	45/47	13	95-115
18	43659	18	5	M12	150	100	10	44	42	Max. 59	49	13	95-115
20-22	66377	20/22	5	M16	155	100	10	50	50	Max. 63/67	51/55	17	190-215
25	43662	25	6	M16	210	100	10	55	54	Max. 72	60	17	190-215
26	63081	26	6	M20	225	150	15	63	62	Max. 83	68	22	355-415
28	43663	28	6	M20	225	150	15	63	62	Max. 85	70	22	355-415
30	63082	30	7	M20	255	150	15	70	69	Max. 87	72	22	355-415
32	43664	32	7	M20	255	150	15	70	69	Max. 92	77	22	355-415
36	43665	36	8	M20	285	150	15	77	74	Max. 99	84	22	355-415
40	43666	40	9	M20	315	150	15	76	74	Max. 101	86	22	355-415

## MOUNTING INSTRUCTIONS FOR ALC-AP COUPLER

- Mount the ALLIGATOR COUPLING to the reinforcement steel.



- Place the ALC-AP coupler over the end of the rebar until the rebar reaches the surface of the plate.
- Tighten the breaking bolt by hand.
- Do not lubricate the bolt connection.
- Mount the bolts as straight as possible.

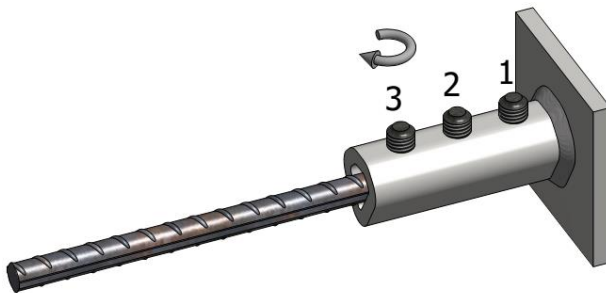

Tighten the breaking bolts completely using an electric or pneumatic wrench as described on page 20-21. The bolts must be tightened from the centre outwards (1 to 3) until the heads of all the breaking bolts shear off.

*Not removing/shearing of a bolt head during installation is acceptable provided the appropriate bolt torque is attained as detailed in the table on page 6. However, the installation is only considered satisfactory if the height H as in the table on page 6 is not exceeded. This must be measured to ensure satisfactory penetration and grip of the reinforcing bar.*

An example of using the ALC-AP – COUPLER is shown in the illustration below



## TRANSITION COUPLER – ALC-VK

The ALLIGATOR TRANSITION COUPLER connects two different diameters of re-bar steel. This coupler can help the designer optimise the structure in a safe and economical manner.

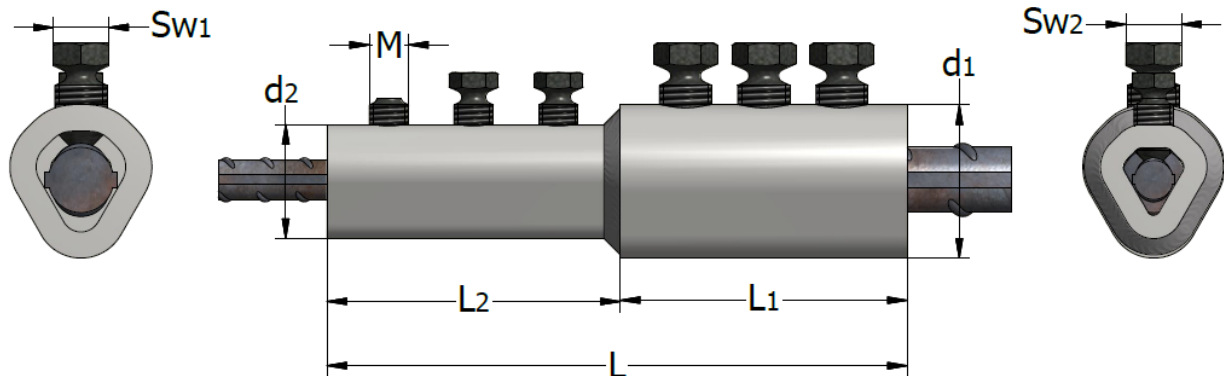

Type ALC-VK	Product no.	Rebar $\varnothing$ [mm]	Breaking bolt number n	Breaking bolt thread M	L [mm]	L1 [mm]	L2 [mm]	d1 [mm]	d2 [mm]	SW1/SW2 [mm]	Max. Torque moment [Nm]
16/10-12	46210	16/10-12	4/3	M12/M12	205	115	90	37	33	13/13	115/115
20/12	44731	20/12	3/3	M16/M12	178	88	90	50	33	17/13	215/115
20/14	43593	20/14	4/4	M16/M12	227	112	115	50	37	17/13	215/115
20/16	44732	20/16	4/4	M16/M12	227	112	115	50	37	17/13	215/115
20/18	64119	20/18	5/5	M16/M12	285	145	140	50	44	17/13	215/115
22/16	63190	22/16	4/4	M16/M12	227	112	115	50	37	17/13	215/115
25/16	44733	25/16	3/4	M16/M12	221	106	115	55	37	17/13	215/115
25/18	64120	25/18	5/5	M16/M12	306	166	140	55	44	17/13	215/115
25/20	44734	25/20	5/5	M16/M16	311	166	145	55	50	17/17	215/215
25/22	48255	25/22	5/5	M16/M16	311	166	145	55	50	17/17	215/215
28/20	64121	28/20	5/5	M20/M16	315	170	145	63	50	22/17	415/215
28/22	64122	28/22	5/5	M20/M16	315	170	145	63	50	22/17	415/215
28/25	48254	28/25	6/6	M20/M16	396	200	196	63	55	22/17	415/215
32/20	44735	32/20	4/5	M20/M16	285	140	145	70	50	22/17	415/215
32/22	64637	32/22	5/5	M20/M16	315	170	145	70	50	22/17	415/215
32/25	44736	32/25	6/6	M20/M16	396	200	196	70	55	22/17	415/215
32/28	48253	32/28	7/6	M20/M20	448	238	210	70	63	22/22	415/415
36/32	61001	36/32	8/7	M20/M20	508	268	240	77	70	22/22	415/415
40/25	61027	40/25	6/6	M20/M16	396	200	196	76	55	22/17	415/215
40/28	48252	40/28	7/6	M20/M20	440	230	210	76	63	22/22	415/415
40/32	44737	40/32	7/7	M20/M20	470	230	240	76	70	22/22	415/415

For the dimensions H (unruptured bolts), please see the table on [page 6](#).

## MOUNTING INSTRUCTIONS FOR ALC-VK COUPLER

- Mount the ALLIGATOR COUPLING to the reinforcement steel from one side.

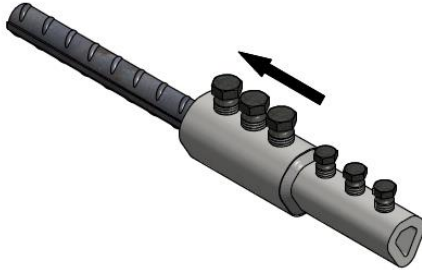

- Place the ALC-VK coupler over the end of first rebar and tighten the breaking bolt by hand.

- Mount the second reinforcement bar in the ALLIGATOR COUPLER and tighten the breaking bolts until they shear off.

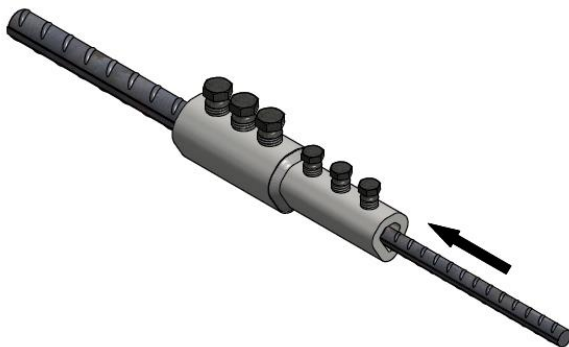

- Insert the second rebar into the coupler until it reaches the first rebar.  
- Do not lubricate the bolt connection.  
- Tighten the breaking bolt by hand.

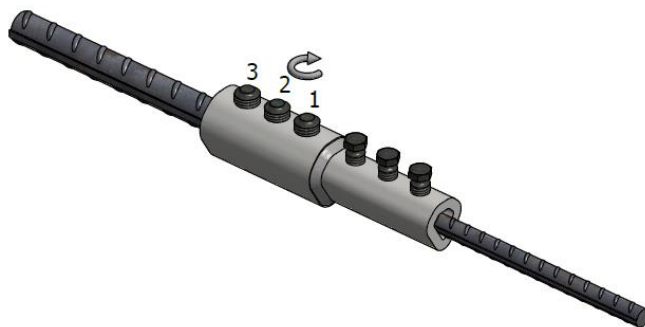

Tighten the breaking bolts completely using an electric or pneumatic wrench as described on page 20-21. The bolts must be tightened from the centre outwards (1 to 3) until the heads of all the breaking bolts shear off.

- The ALLIGATOR COUPLER in mounted state.



Completed ALC-VK coupler installation after all bolts have been sheared off.  
Not removing/shearing of a bolt during installation is acceptable provided the appropriate bolt torque is attained as detailed in the table on page 6. However, the installation is only considered satisfactory if the height  $H$  as in the table on page 6 is not exceeded. This must be measured to ensure satisfactory penetration and grip of the reinforcing bar.

## CONTINUITY COUPLER – ALC-SK

The ALLIGATOR CONTINUITY COUPLER allows reinforcement to be extended at construction joints without the need to drill the formwork at the construction joint locations. The female part of the coupler is attached to the formwork with the aid of a threaded nailing plate. After removal of the formwork and the nailing plate, the male part of the coupler can be screwed into the installed part of the coupler. The ALC-SK coupler male component has one threaded bolt and two additional locknuts mounted on it, which are used to secure the connection. The male part of the ALC-SK coupler can be replaced by a TSE coupler with a metric thread of the same size.

These couplers are also suitable for precast concrete element connections.

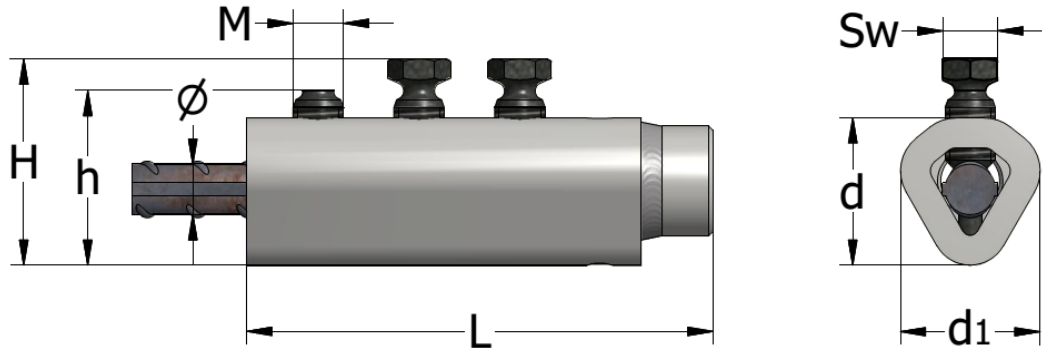

Type ALC-SK	Product no.	Rebar Ø [mm]	Breaking bolt number n	Breaking bolt thread M	L [mm]	d [mm]	d1 [mm]	H Unruptured Bolt [mm]	h [mm]	Bush thread	SW [mm]	Torque moment [Nm]
12	45745	12	3	M12	117	33	34	Max. 49	39	M16	13	95-115
16	45746	16	4	M12	156	37	38	Max. 57	47	M20	13	95-115
20	43578	20	5	M16	198	50	50	Max. 63	51	M24	17	190-215
25	45747	25	6	M16	255	55	54	Max. 72	60	M30	17	190-215
32	45748	32	7	M20	318	70	69	Max. 92	77	M42	22	355-415
40	45749	40	9	M20	379	76	74	Max. 101	86	M48	22	355-415

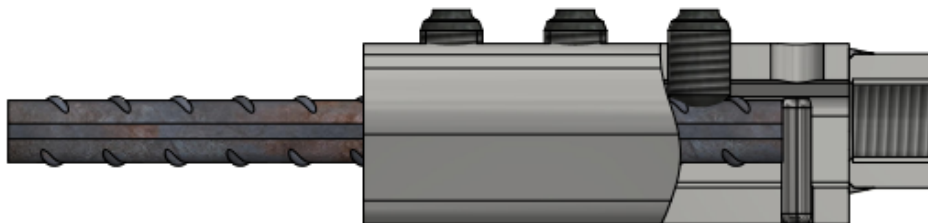

### CONTINUITY COUPLER – PSK – MALE COMPONENT

The PSK Male coupler is used to connect two ALC-SK couplers. It consists of a threaded bar with two hexagonal nuts for blocking and securing the system.

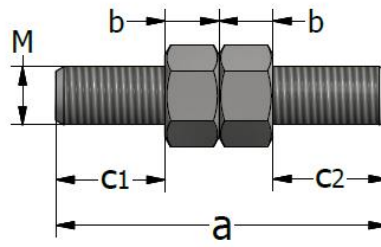

PSK	Product no.	Rebar Ø [mm]	Bolt thread	a [mm]	c1 [mm]	c2 [mm]	b [mm]
M16	63157	12	M16	80	24	30	13
M20	63158	16	M20	115	37	46	16
M24	63159	20	M24	140	47	55	19
M30	63160	25	M30	170	56	66	24
M42	63161	32	M42	247	83	96	34
M48	63162	40	M48	260	86	98	38

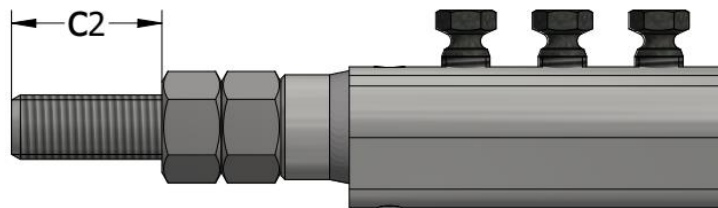

## PLASTIC NAILING PLATE KU-10

The KU-10 nailing plates are used for affixing the ALC-SK coupler to the formwork with nails. The fixing flange ensures a minimal recess around the thread bush coupler. The recess is filled with fine concrete for protection against corrosion.



KU-10	Product no.	Thread	Diam. D	Diam. d	s	Colour
		M	[mm]	[mm]	[mm]	
KU-10-M12	63246	12	47	37	10	Red RAL 3020
KU-10-M16	63256	16	47	37	10	Grey RAL 7043
KU-10-M20	63257	20	60	50	10	Green RAL 6024
KU-10-M24	63258	24	60	50	10	Blue RAL 5017
KU-10-M30	63259	30	73	63	10	Light grey RAL 7004
KU-10-M36	63260	36	73	63	10	Orange RAL 2009
KU-10-M42	63261	42	96	86	12	Yellow RAL 1023
KU-10-M48	63131	48	96	86	12	White RAL 9003

Plastic nailing plates KU-10 are nailed to formwork. Using forming wax on the nailing plate makes it easier to remove and screw on an anchor or fixing insert. The ALC-SK coupler must be fastened to the reinforcement by suitable means so that it does not move during concreting. After stripping, unscrew.

### DOUBLE THREADED SCREW PLUG SN

SN threaded screw plug is used to affix the ALC-SK to the formwork. The external thread fits inside the ALC-SK threaded bush and the inner diameter to secure the attachment to the formwork using a standard threaded bolt.

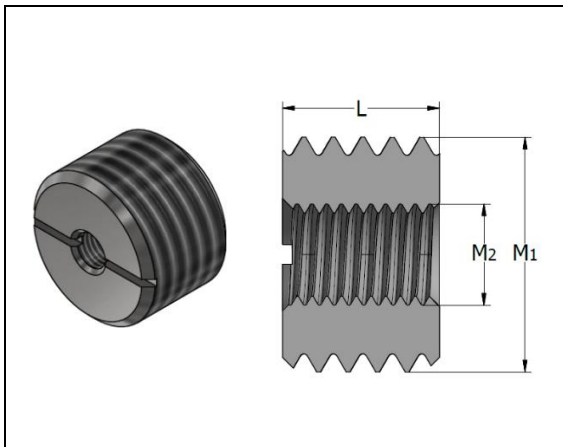

SN	Product no.	Thread		L [mm]
		M1	M2	
SN M12-M6	45214	12	6	16
SN M16-M8	45215	16	8	16
SN M20-M8	45216	20	8	16
SN M24-M8	46303	24	8	16
SN M24-M10	45217	24	10	16
SN M30-M10	45218	30	10	16
SN M30-M8	46079	30	8	16
SN M36-M10	45219	36	10	25
SN M42-M10	45220	42	10	30
SN M48-M10	45464	48	10	36
SN M48-M12	46525	48	12	36
SN M48-M16	46524	48	16	36

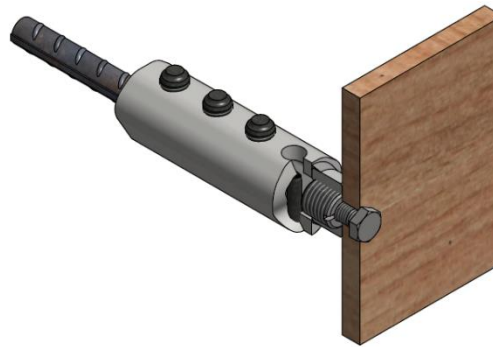



## MOUNTING INSTRUCTIONS FOR ALC-SK COUPLER WITH TSE COUPLER

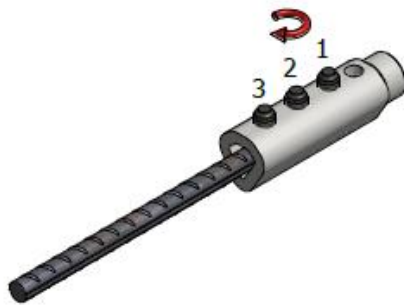

- Place the ALC-SK coupler over the end of the rebar.
  - Check the contact between the rebar and the pin and tighten the breaking bolt by hand.
- Tighten the breaking bolts completely using an electric or pneumatic wrench as described on page 20-21. The bolts must be tightened from the centre outwards (1 to 3) until the heads of all the breaking bolts shear off.

Not removing/shearing of a bolt head during installation is acceptable provided the appropriate bolt torque is attained as detailed in the table on page 6. However, the installation is only considered satisfactory if the height H as in the table on page 6 is not exceeded. This must be measured to ensure satisfactory penetration and grip of the reinforcing bar.

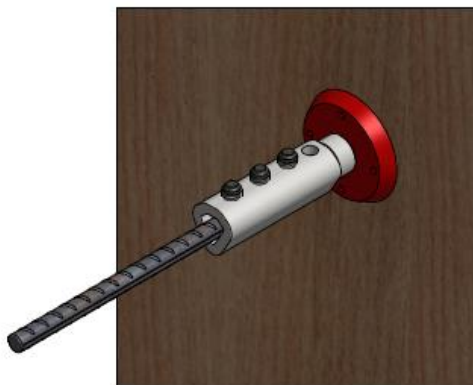

- Attach the nail plate to the formwork and screw the ALC-SK onto the plate.

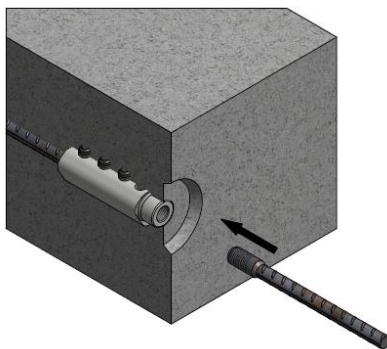

- Remove the formwork and unscrew the nailing plate.
- Screw the TSE coupler completely into the already fixed component.

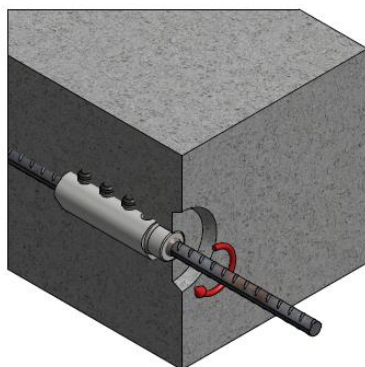

- Tighten the TSE coupler completely using a Terwa torque wrench.
- The torque values are specified in the table on page 19.

## MOUNTING INSTRUCTIONS FOR ALC-SK COUPLER



- Place the ALC-SK coupler over the end of the rebar.
- Check the contact between the rebar and the pin and tighten the breaking bolt by hand.
- Tighten the breaking bolts completely using an electric or pneumatic wrench as described on page 20-21. The bolts must be tightened from the centre outwards (1 to 3) until the heads of all the breaking bolts shear off.

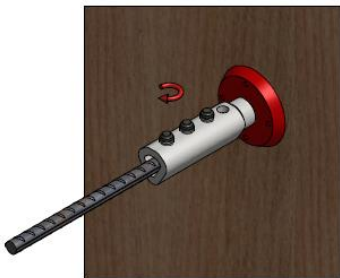

- Attach the nail plate to the formwork and fully screw the ALC-SK onto the plate.

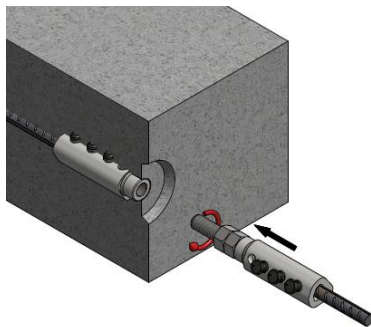

- Remove the formwork and unscrew the nailing plate.
- Mount the second ALC-SK on the second rebar and tighten the breaking bolts by hand.
- Fully screw the PSK male component into the ALC-SK coupling mounted on the second rebar.

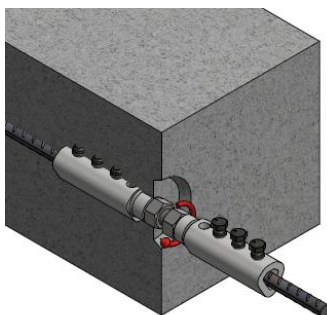

- Screw the threaded rod of the PSK coupling into the ALC-SK coupling already embedded in concrete.
- Rotate until the shear bolts of the second ALC-SK coupling reach an accessible position for tightening.
- Run the first locknut along the threaded bolt until it reaches the ALC-SK embedded in concrete.
- Tighten the locknut completely using a wrench.

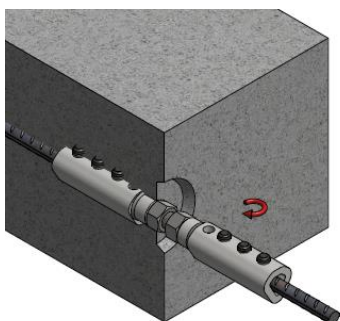

- Tighten the breaking bolts completely using an electric or pneumatic wrench as described on page 20-21.

## TERWA TORQUE WRENCH

The Terwa torque wrench is specially designed for correctly mounting the Terwa coupler on site and at the factories. All Terwa wrenches are delivered with a calibration report and work instructions.

The torque values for all rebar diameters are marked on the wrench. The torque values for all Terwa couplers are listed below.

Reinforcement diameter [mm]	Necessary torque for each type of rebar [Nm]	Setting torque using wrench Mt [Nm]
10	50	60
12	60	60
14	70	60
16	80	60
18	90	70
20	100	75
22	110	82
25	125	93
28	140	104
32	160	119
40	200	148



TERWA torque wrench

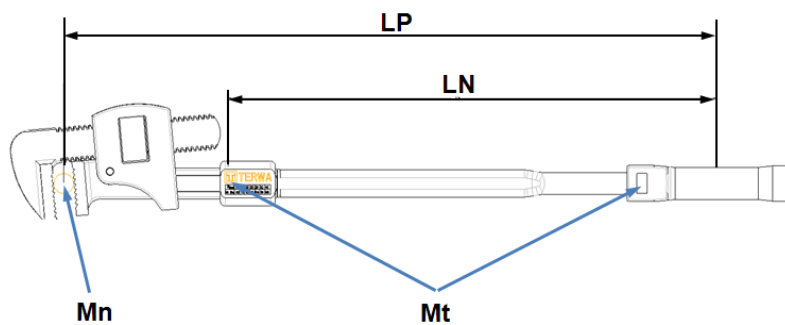

*Mn – required torque*  
*Mt – setting torque using wrench*  
*LP – length to middle of each reinforcement steel*  
*LN – standard length wrench*

$$Mt = Mn \times LN / LP$$

TERWA wrench dimensions

## TOOLS FOR ALLIGATOR COUPLERS

- Use a high-speed, high-impact electric torque wrench or pneumatic wrench – we recommend a minimum of 1000 Nm.
- Try to prevent additional momentum when mounting/shearing off the bolts.
- When using an air impact wrench, check the air pressure, torque rating and air flow requirements before starting the installation process.
- Removing/shearing off bolt heads is not required if appropriate bolt torque is attained. In this case, please consult the table on page 6; the minimum height “H” has to be reached.
- When there is not enough space in the element to use a pneumatic or electric wrench, a handheld torque wrench can be used to shear the bolt or to attain the torque momentum according to the table on page 6. The wrench momentum has to be a minimum of 2x the breaking bolt torque.
- Using hardened, heavy-duty sockets with a maximum external diameter is recommended; see the table below.

Type ALC	Breaking bolt Thread M	SW / [mm]	Maximum socket wrench diameter /[mm]		
10	M12	13	Ø 26		
12, 14-16, 18	M12	13	Ø 36		
20	M16	17	Ø 27		
22, 25	M16	17	Ø 39		
28, 32, 36, 40	M20	22	Ø 33		

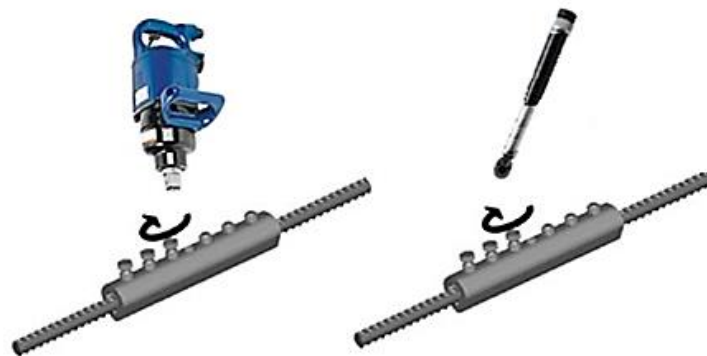

The above-mentioned wrenches with the tooling necessary for shearing off bolts M12, M16 and M20 are available in boxes.



60627

ALC Electric Mounting Kit



60626

ALC Pneumatic Mounting Kit

Aluminium box	Product no.	Type wrench	Torque moment (NM)
1	60627	Electric	1000
2	60626	Pneumatic	1000-1898



## CONTACT



TERWA is the global supplier for precast and construction solutions with multiple offices around the world. With all our staff, partners and agents, we are happy to provide all construction and precast companies who work in the building industry with full service and 100% support.

### TERWA CONSTRUCTION GROUP

#### Terwa Construction Netherlands (HQ)

**Global Sales & Distribution**  
Kamerlingh Onneslaan 1-3  
3401 MZ IJsselstein  
The Netherlands  
**T** +31-(0)30 699 13 29  
**F** +31-(0)30 220 10 77  
**E** [info@terwa.com](mailto:info@terwa.com)

#### Terwa Construction Central East Europe

**Sales & Distribution**  
Strada Sânzieni  
507075 Ghimbav  
Romania  
**T** +40 372 611 576  
**E** [info@terwa.com](mailto:info@terwa.com)

#### Terwa Construction Poland

**Sales & Distribution**  
Ul. Cicha 5 lok. 4  
00-353 Warszawa  
Poland  
**E** [info@terwa.com](mailto:info@terwa.com)

#### Terwa Construction India & Middle East

**Sales & Distribution**  
India  
**T** +91 89 687 000 41  
**E** [info@terwa.com](mailto:info@terwa.com)

#### Terwa Construction China

**Sales & distribution**  
B05, 5F, No. 107, 2nd of the South  
Zhongshan Road  
200032 Shanghai  
China  
**E** [info@terwa.com](mailto:info@terwa.com)

**ALL SPECIFICATIONS CAN BE CHANGED WITHOUT PREVIOUS NOTICE.**

### DISCLAIMER

Terwa B.V. is not liable for deviations due to wear of the products it has delivered. Neither is Terwa B.V. liable for damage due to inaccurate and/or improper handling and use of the products it has delivered and/or use of same for purposes other than those intended.

Terwa B.V.'s responsibility is furthermore limited in accordance with article 13 of the "Metaalunie" conditions, which are applicable for all Terwa B.V. deliveries. The user is responsible for ensuring compliance with all applicable copyright laws.

Without limiting the rights under copyright, no part of this documentation may be reproduced, stored in or introduced into a retrieval system, or transmitted in any form or by any means (electronic, mechanical, photocopying, recording, or otherwise), or for any purpose, without the express written permission of Terwa B.V.